

Drive and Return Units

## Section 3—Drive and Return Units

TS4plus drive units power the roller chain along the conveyor sections and help maintain proper chain tension. The return units route the roller chain back through the return channel of the chain profile. Drives and returns can also be linked together end-to-end to create extended conveyor lines of almost any length without loss of capacity.

Two types of drive units are available, depending on load requirements for the system.

Different motor electrical options, motor mounting positions, chain tensioners, and transport speeds allow you to configure the drive to suit your needs.

3

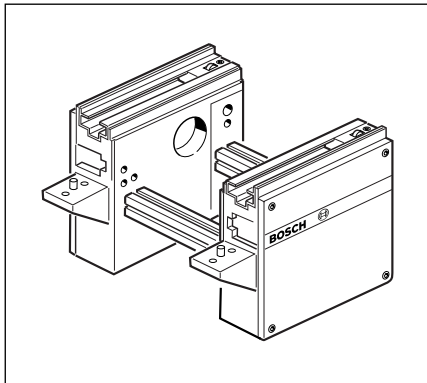

**UM4S**  
Return Unit  
3-1

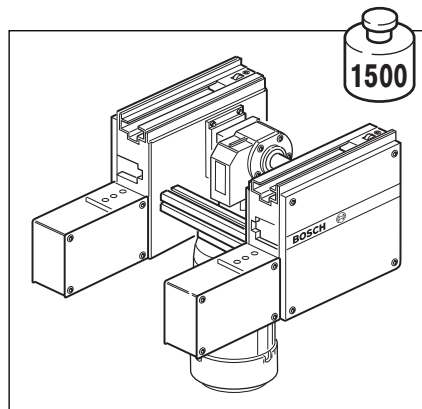

**AS4S/S**  
Standard Drive Unit  
3-2 to 3-3

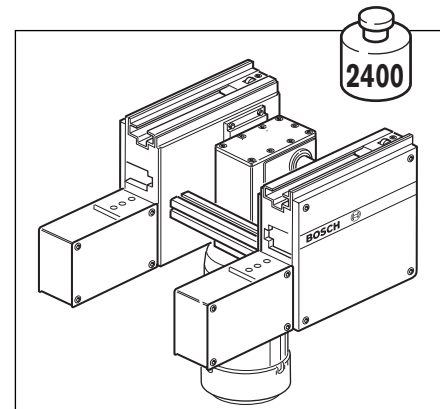

**AS4S/H**  
Heavy-Duty Drive Unit  
3-4 to 3-5

Drive and Return Units

**Return Unit UM4S**

The TS4plus return unit routes the roller chain from the transport level to the return channel inside the chain section profile, where it is fed back to the drive module. Return units are available in standard widths to match the drive module, and can be used with either standard or heavy-duty drives.

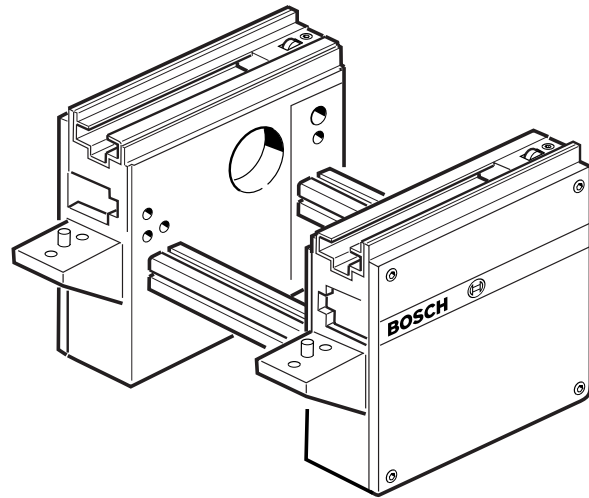

**Ordering Information for Return Unit UM4S**

Width in mm (Bwt)	Part Number
443	<b>8981 019 495</b>
643	<b>8981 019 496</b>
843	<b>8981 019 497</b>
1043	<b>8981 019 498</b>
1243	<b>8981 019 499</b>

**Dimensional Data for UM4S**

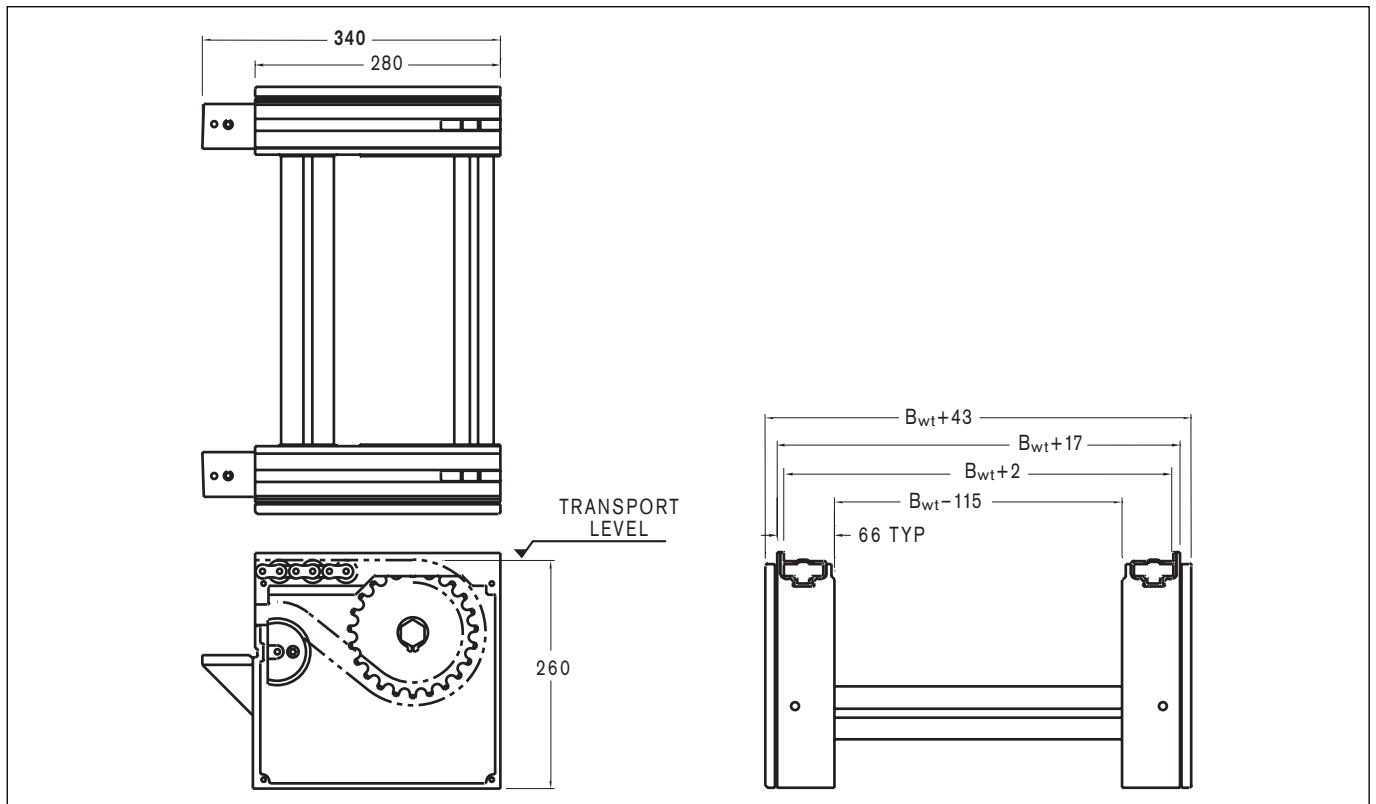

Drive and Return Units

# Standard Drive Unit

## AS4S/S

The TS4plus standard drive module is used to pull the roller chain along the chain section at a constant speed. Drives are available with the motor/gearbox mounted between the conveyor rails (mid-mount) or outside the rails on the left or right side. Standard speed and voltage combinations are listed in Table 3-1.

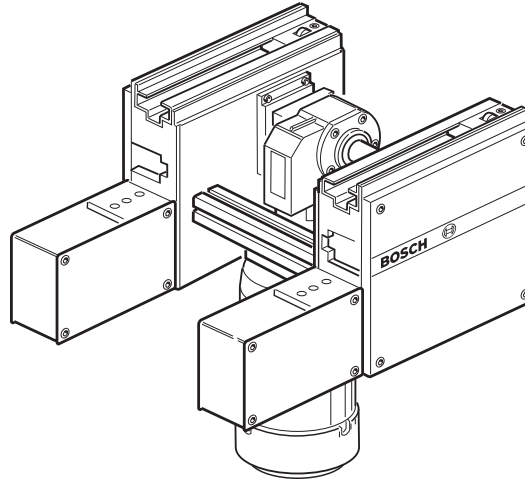

**3** Each drive module includes a chain tensioner. Normally, a spring tensioner with 80 mm of travel is used to provide automatic tensioning of the chain during operation. However, fixed tensioners are also available for conveyors under 4000 mm in length and reversing applications. Chain tensioners include a bracket which can be used to mount a 12 mm proximity switch (ordered separately) to sense the end of tensioner travel.

Standard drives are rated for a maximum total payload of 1,500 kg per drive. For heavier loads, a heavy-duty drive module is available (page 3-4), or shorter conveyor sections with additional drive and return modules can be added. Hardware for connecting drive and return modules end-to-end is included.

**Motor Position**

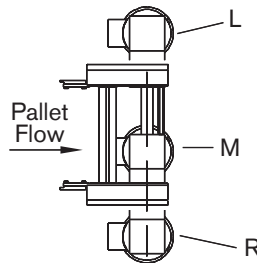

**Motor Orientation**

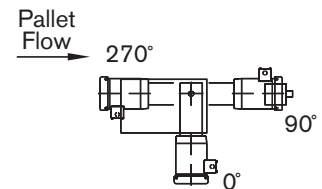

### Ordering Information for Standard Drive Unit AS4S/S

In addition to part number, please specify: ↓	AS4S/S Standard Drive Unit 8981 999 219	
	Your choices are:	Your selection:
Drive Unit width (B)	443, 643, 843, 1043, 1243	_____ mm
Nominal speed*	12, 15	_____ m/min.
Motor voltage/frequency <sup>†</sup>	See Table 3-1	_____ V ____ Hz
Tensioner Type	S= Spring F= Fixed**	_____
Motor Orientation	0°, 90°, 270°	_____
Motor Position	L, M, R	_____

\*Full load conveyor speeds vary depending on motor frequency. See Table 3-1

\*\*Fixed tensioner required for reverse operation

<sup>†</sup>To omit motor, specify 000V 00Hz

Drive and Return Units

**Technical data for AS4S/S**

Nominal conveyor speed	=	See Table 3-1
Permissible loading weight	=	1500 kg
Maximum conveyor unit length	=	20 m (65 ft.)
Motor RPM at 50 Hz	=	1400
Motor RPM at 60 Hz	=	1700
Motor, electrical specifications	=	See Table 3-1

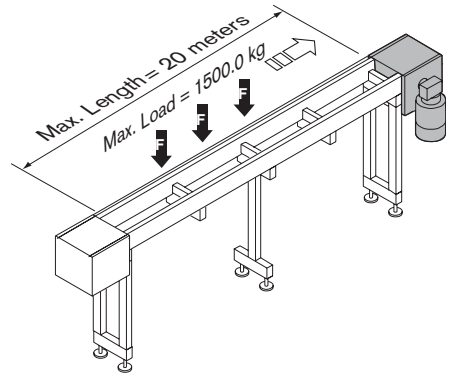

**Electrical data for AS4S/S**

Nom. M/min	Actual Speed		HP	Full Load Amps @					
	50 Hz	60 Hz		208/60	240/60	380/50	415/50	480/60	575/60
12	9.8	11.9	0.50	1.8	1.9	0.78	0.72	0.84	0.71
15	12.8	15.6	0.50	1.8	1.9	0.78	0.72	0.84	0.71

Table 3-1

Note: Electrical Data for reference only. Refer to motor data plate for actual ratings.

**Dimensional data for AS4S/S**

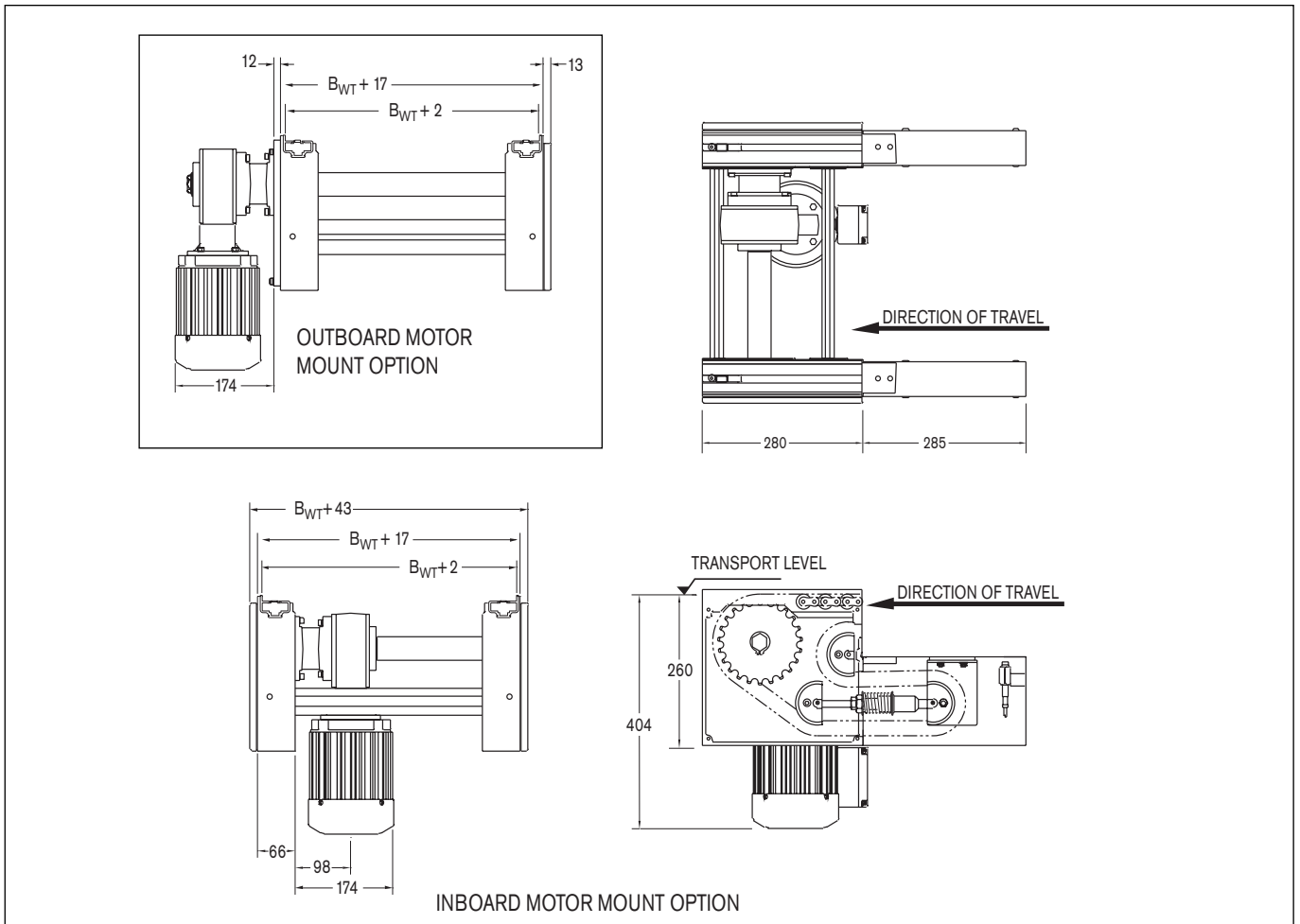

Drive and Return Units

# Heavy-Duty Drive Unit

## AS4S/H

The TS4plus heavy-duty drive module is used to pull the roller chain along the chain section at a constant speed. Drives are available with the motor/gearbox mounted between the conveyor rails (mid-mount) or outside the rails on the left or right side. Standard speed and voltage combinations are listed in Table 3-2.

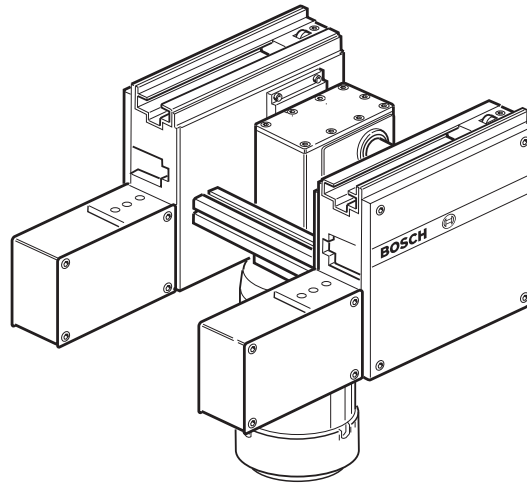

**3** Each drive module includes a chain tensioner. Normally, a spring tensioner with 80 mm of travel is used to provide automatic tensioning of the chain during operation. However, fixed tensioners are also available for conveyors under 4000 mm in length and reversing applications.

Chain tensioners include a bracket which can be used to mount a 12 mm proximity switch (ordered separately) to sense the end of tensioner travel.

Heavy-duty drives are rated for a maximum total payload of 2,400 kg per drive. For heavier loads, shorter conveyor sections with additional drive and return modules can be added. Hardware for connecting drive and return modules end-to-end is included.

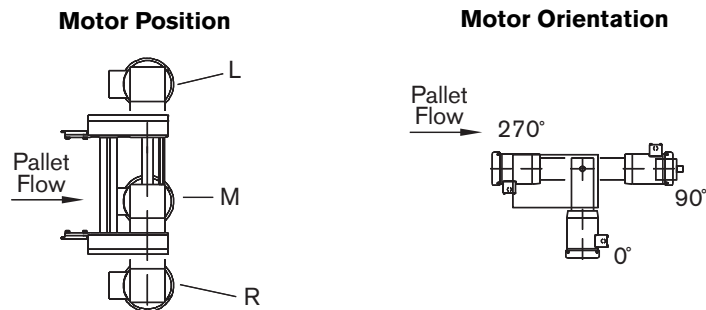

### Ordering Information for Heavy-Duty Drive Unit AS4S/H

In addition to part number, please specify: ↓	AS4S/H Heavy Duty Drive Unit 8981 999 197	
	Your choices are:	Your selection:
Drive Unit width (B)	443, 643, 843, 1043, 1243	_____ mm
Nominal speed*	6, 9, 12, 15, 18	_____ m/min.
Motor voltage/frequency <sup>†</sup>	See Table 3-2	_____ V _____ Hz
Tensioner Type	S= Spring F= Fixed**	_____
Motor Orientation	0°, 90°, 270°	_____
Motor Position	L, M, R	_____
Flange Mounting <sup>‡</sup>	I= IEC 105/IEC120 N= NEMA 56C	_____

\*Full load conveyor speeds vary depending on motor frequency. See Table 3-2

\*\*Fixed tensioner required for reverse operation

<sup>†</sup>To omit motor, specify 000V 00Hz

<sup>‡</sup>Required for no motor option

Drive and Return Units

**Technical data for AS4S/H**

Nominal conveyor speed	=	See Table 3-2
Permissible loading weight	=	2400 kg
Maximum conveyor unit length	=	20 m (65 ft.)
Motor RPM at 50 Hz	=	1400
Motor RPM at 60 Hz	=	1700
Motor, electrical specifications	=	See Table 3-2

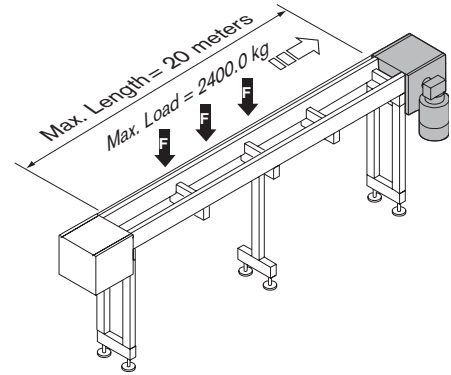

**Electrical data for AS4S/H**

Nom. M/min	Actual Speed		HP	Full Load Amps @					
	50 Hz	60 Hz		208/60	240/60	380/50	415/50	480/60	575/60
6	6.8	8.3	0.5	1.8	1.9	0.78	0.72	0.84	0.71
9	8.5	10.4	0.5	1.8	1.9	0.78	0.72	0.84	0.71
12	10.6	12.9	0.75	2.9	2.9	1.6	1.6	1.6	1.1
15	12.5	15.2	0.75	2.9	2.9	1.6	1.6	1.6	1.1
18	17.7	18.8	0.75	2.9	2.9	1.6	1.6	1.6	1.1

Table 3-2

Note: Electrical Data for reference only. Refer to motor data plate for actual ratings.

**Dimensional Data for AS4S/H**

